



inOKiM

Urban Freedom



Electric



Personal



Mobility

USER GUIDE MANUAL

MODEL : LIGHT

INOKIM

LIGHT

We want our users to be confident that they can unfold and use INOKIM LIGHT or fold and store it within seconds.

We wish one will not hesitate on keeping INOKIM on here/his car trunk regularly or taking it with him on any kind of trip, even if She/he dose not mean to use it, maybe they will fined it useful unexpectedly.



Warnings & General information	2-3
LIGHT Features	5
LIGHT Main Parts	6-7
Serial Number	8
Opening & Folding	9-15
Operation	16
Charging & Battery	17
Throttle	18-21
Safety and Tire Pressure	22
Driving Technique	23-24
LIGHT Maintenance	25
Folding mechanism adjustment	28-29
Removing Rear Plastic Covers	30

READ THIS MANUAL

IMPORTANT INFORMATION

WHY IS IT NECESSARY TO READ THIS USER MANUAL ?

This Manual was written to help you understand the proper use and maintenance of INOKIM LIGHT electric scooter.

It is important for you to understand your new INOKIM; its features and performance, so that you will enjoy the most from your first and every ride.

Also, it is important that your first ride with INOKIM LIGHT will be in a remote location, without any obstacles.

The Inokim requires a short adjustment and break-in period for all moving parts to adjust themselves into their correct position"
Before Riding: Ensure that the Folding Lever is firmly locked in place and that the safety lock is on.

WARNING !

The responsibility for INOKIM LIGHT maintenance is yours, and will help reduce risks of injuries.

Therefore, read this manual and follow it's instructions, they will help you avoid these risks.

DISCLAIMER

MYWAY EV LTD is not liable for any accidental damages related to the use of this product.

BEFORE RIDING:

Ensure that the **Folding Lever** of the folding mechanism is firmly locking the folding mechanism and that **Safety Lock** is on.

GENERAL WARNING

- Wear a helmet when riding INOKIM
- Always follow the local laws and regulations.
- Never ride your scooter in conditions of poor visibility.
- Do not do stunts, wheelies or jumps. They will increase your chances of injury and damage your INOKIM.
- Do not carry passengers.

LIGHT

LIGHT APPEARANCE



LIGHT FEATURES

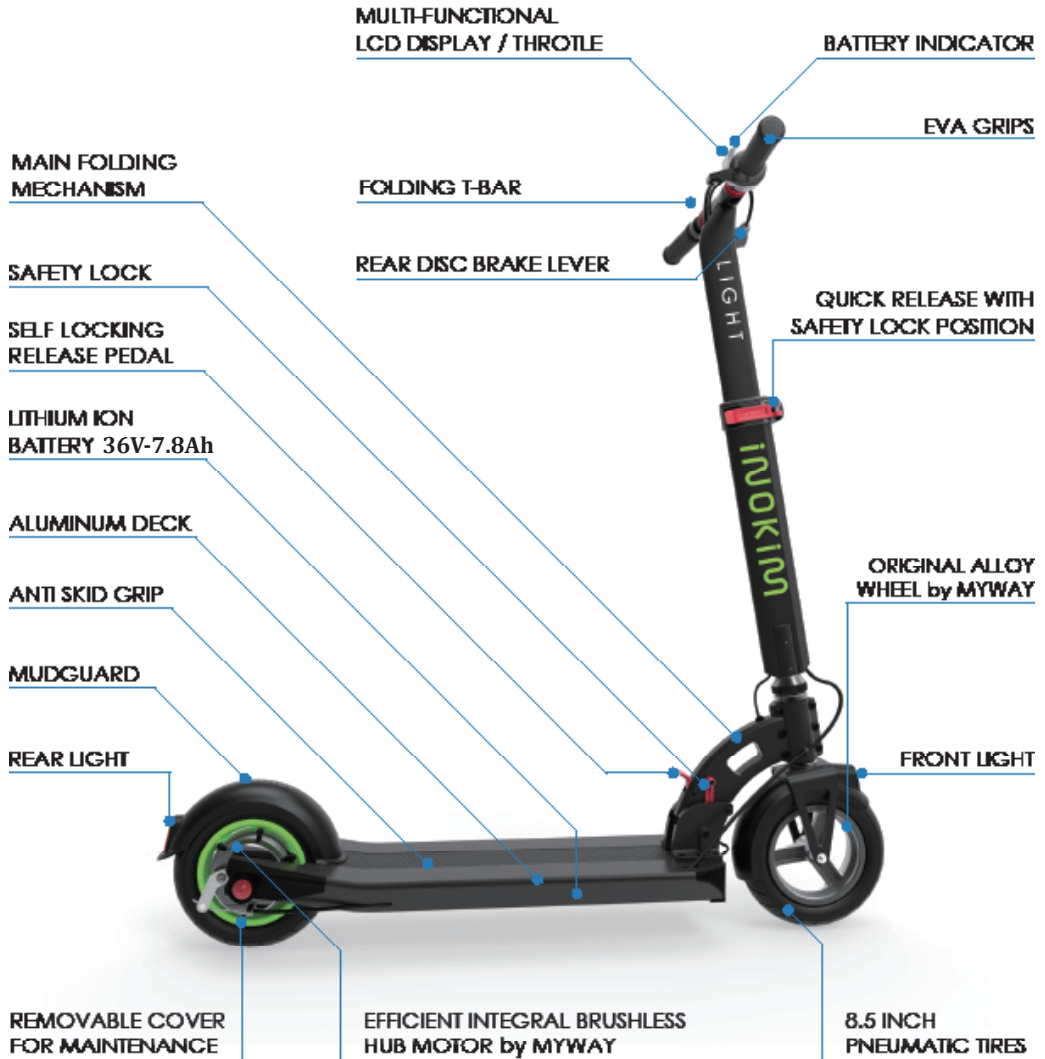

LIGHT MAIN PARTS



QUICK FOLDING MECHANISM
SELF LOCKING / RELEASE BUTTON



INOKIM WHEEL ELECTRIC MOTOR



ALUMINIUM DECK WITH ANTI SKID GRIP



INNER DRUM BRAKE / AUTO
POWER OFF



BATTERY CHARGER CONNECTOR

LIGHT MAIN PARTS

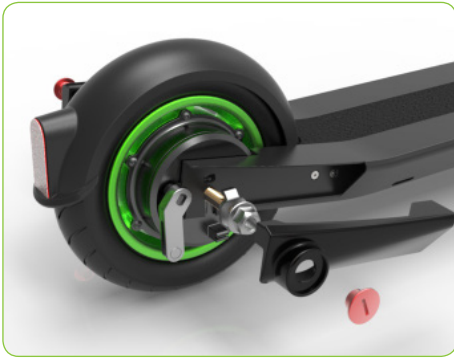

MAINTENANCE PLASTIC COVER



SPEED CONTROL THROTTLE WITH LCD DISPLAY AND FUNCTIONS



FOLDED POSITION



QUICK RELEASE



KICKSTAND POSITION

RECORD SERIAL NUMBERS:

Write down the serial number of your LIGHT scooter. Keep this information separately and in a safe place.

Each INOKIM has a unique serial number. These numbers can provide information that may be useful later on for insurance claims and in case of loss or theft.

To find your INOKIM serial number:

1. The number is on the top right side of the board, near folding mechanism.
2. Note the serial number and keep it in a safe place.



OPENING AND FOLDING LIGHT

OPENING LIGHT

1

Press down the RED Pedal using your hand



Self Locking Pedal



2

Pull up and push out the steering rod and hear the click of locking mechanism



OPENING LIGHT

3

Unfold handlebars and lock them with the **RED** side rings



See tightening direction

4

Open the **RED** quick release and slide the steering rod up to its locking position



Make sure the safety latch is inserted into its place

OPENING LIGHT

5

Last step is to ensure RED SAFETY LOCK is securing the FOLDING MECHANISM



SAFETY lock positions

OFF



ON

Kickstand position



Folding mechanism at Kickstand position

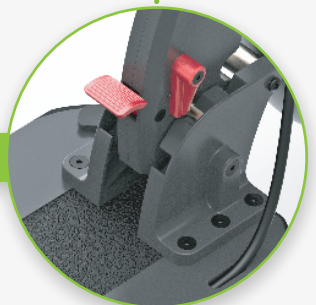

1

To fold INOKIM LIGHT, depress the **RED** safety lock first

Push the steering bar firmly forward while at the same time using your foot to push the **RED** pedal down to release the folding mechanism

Push pedal down using your foot

**NOTICE:**

INOKIM LIGHT has a unique folding mechanism, which enables a quick and easy fold for carrying, transportation and storage.

Folding the LIGHT Scooter is as simple as Opening it. (see page 10)

2



3



4



BATTERY:

- Do not operate the scooter while charging!
- Do not store the INOKIM for long periods of time with a fully charged battery. If scooter is not in use for more than one month, keep it under half way charged.
- From time to time Discharge the battery by riding INOKIM using all stored energy in the battery.

DO NOT USE THE BATTERY IF THE BOARD:

- Is Broken
- Emits an unusual odour or excessive heat
- Presents any leakage.

Avoid contact with substance oozing from the battery.
Keep the battery away from children and pets. Exposure to the battery voltage can cause death or serious injury.

The use, storage or charging of the INOKIM battery outside specified limits may result in the annulment of the warranty, battery damage, and an ineffective battery charging.



CHARGING AND BATTERY:

Your INOKIM scooter has an external charger. Connect the charging cable to INOKIM's charging socket on top of foot-board, on the left front side.

Then connect the charger's electric cable to an electrical outlet.

Charging Light **Red** - Battery is charging.

Charging Light **Green** - Charging is complete.

Avoid long periods of time with an uncharged or fully charged battery.

To maximize your INOKIM's battery performance, fully charge it for 8 hours, once a month.

Unplug INOKIM from the outlet before installing, removing the battery or performing any maintenance. It is dangerous to work on INOKIM when plugged into an AC outlet. Electrical shock can cause serious injury and damage the scooter.

Do not attempt to open the battery. Do not insert anything in the battery and do not attempt to open its case with any tool. Inserting an object into openings or in the battery can cause electrical shock, injury, burns or fire. Any attempt to open the battery case will damage it and cause release of dangerous toxic substances.

Charge the battery only using tools approved by INOKIM. Remove the battery and carry INOKIM according to all applicable local and national requirements.



THROTTLE OPERATION

LCD DISPLAY



THROTTLE FUNCTIONS

- travel speed
- cruise control
- distance
- battery status
- speed mode
- Total trip
- background light
- automatic power-off
- ODO

THROTTLE BUTTONS INTRODUCTION



+ Button

⏻ ON/OFF button

- Button

ACCELERATE thumb button

THROTTLE POWER ON

Press  to power the scooter on.

THROTTLE POWER OFF

Press  for three seconds to shut down the system.



AUTO POWER OFF

After five minutes of non using any function, the scooter will automatically shut down.

DRIVE / SPEED CONTROL

Start twisting the thumb throttle with your thumb for accelerating. Max twisting angle 60° for full speed.



SPEED MODE

When power is on 

The default display is **SPEED** mode (appear at top right).

You may change it using the   buttons.

Speed mode: this function is to limit the maximum speed of the scooter, either for a beginner user or for more accurate riding in a crowded surrounding:



- **speed mode 3** - using full throttle will gain maximum speed of the scooter, 25KM/H at default.
- **speed mode 2** - using full throttle, will gain 70% of scooter top speed.
- **speed mode 1** - using full throttle, the maximum speed will be under 10 KM/H

SETTINGS - DISPLAY MODES

To enter the display modes settings :

Touch  buttons together for 2 seconds will enter in the *first mode*.

Press  to switch between modes

Long press  will back to main function menu.

- LCD BACKLIGHT (*first mode*)

When power is on, you can open or close the LCD backlight by long press 

There are 3 levels for different LCD brightness.

Press  to change level from 1 to 3 (low/middle/high).



Long touch  to save settings.

Short touch  to enter *second mode*.

- SPEED LIMIT MODE (*second mode*)

Default and highest speed **25KM/H** at full throttle.

You can define other speed limits (from 6KM/H to 35KM/H).

Press  or  buttons to change speed limit number.



Long touch  to save setting.

Short touch  to enter *third mode*.

DISPLAY MODES

• CRUISE CONTROL (*third mode*)

The default setting is Cruise Control off (letter "n" for **No Cruise Control** to indicate).

Press or  to  choose enable Cruise Control (Letter "Y"  to indicate **Yes Cruise Control**).

Long touch  to save setting.

Short touch to enter *first mode*.

• TRIP RESET

Reset TRIP by long press 

OTHER DISPLAY MODES ARE:

- TRIP- your trip distance since your last trip reset. Press  to swap.
- ODO - your scooter total distance since its factory assembled, or new / repaired battery was placed.
- Battery voltage - Your battery state.
- Error - your system has encountered an error, please contact your local dealer to find out what it is.

CRUISE CONTROL

While riding at any same speed for more than Ten (10) seconds, the Cruise Control will be turned on, (If this option is defined in "SETTINGS", it does not come as a default for safety reasons).

When Cruise Control is operated, you can release your thumb from the throttle and the scooter will continue to ride at full speed.

To slow down, simply apply pressure on one of the brake levers or press the throttle again, the Cruise Control will be turned off.

When riding with cruise control and braking, Cruise Control system powers off.

WARNING!

Please be aware that when using Cruise Control system, releasing your thumb from the throttle will not slow you down, you may find yourself in danger or in danger of others.

WARNING !

Certain countries or regions require safety devices or gear. It is your responsibility to know the state laws, and follow them.

TIRES AIR PRESSURE

Air pressure in tires: 40psi to 50psi.

SAFETY GEAR

Helmet: most serious injuries that occur while riding are head injuries. This could have been prevented if a helmet had been worn.

You must wear a helmet while riding your LIGHT - 2 . The helmet must be worn according to its instructions.

MECHANICAL SAFETY TESTS:

Before using LIGHT - 2 : Perform a visual inspection that all screws and nuts are tight and in place. Note if anything looks amiss, or is showing signs of wear. If you are unsure, bring your LIGHT - 2 to the authorized distributor.

Tires and wheels: check the tires for signs of wear. To do this- spin them to make sure that they are not yet in the need of replacing. Make sure that the wheels are freely rotating from the brakes. If not, take Your INOKIM to the authorized distributor.

Before each ride, always check your brakes and mechanical function.

TIP

As you accelerate, lean forwards.
As you brake, tilt your weight backwards !

SAFE DRIVING:

1. Get to know LIGHT - 2 before driving it. Test your control over it. Make your turns slowly and cautiously, and give yourself stopping distance.
2. Your driving capability - to gain control over your scooter, practice your first ride on LIGHT - 2 in an open space with no obstacles to disturb you.

DRIVING TECHNIQUE:

Foot Position - before riding put your foot as close as possible to the front section of the scooter, and your other foot on the ground. Make sure that your driving route is clear.

To start riding boost yourself forwards (as on non-motorized scooters) with your foot that is on the ground.

Immediately after press the thumb throttle downwards, tilt your body forwards so you shouldn't fall backwards during acceleration. LIGHT - 2 will be in motion.

Avoid your body pressure on the handle bars in acceleration and deceleration!

Keep one foot behind the other, (it's more comfortable to place one foot forward and the other one turned backwards at 70-90°, like on skate/surfboard). It will help you gain more stability.

NOTICE

Riding, like most sports, involves risks of injury and damage. By choosing to ride INOKIM the responsibility and all inherent risk is on you. It is crucial that you know, understand and act according to safety rules.

DRIVING TECHNIQUE:

Turns - The turns on INOKIM are done as on surf/ski/snowboard. The handlebar should be in parallel to the body. Before turning look at the approaching direction and make sure turning is safe.

Braking - Tilt your weight backwards so that the brake action will come through the feet and not trough the handlebar and steering system.

It is best to learn how to adjust the centre of gravity during Stopping, otherwise there is a dual concern: forward turning over, ("Stopy") and/or wear and breaking of the handlebar and steering system.



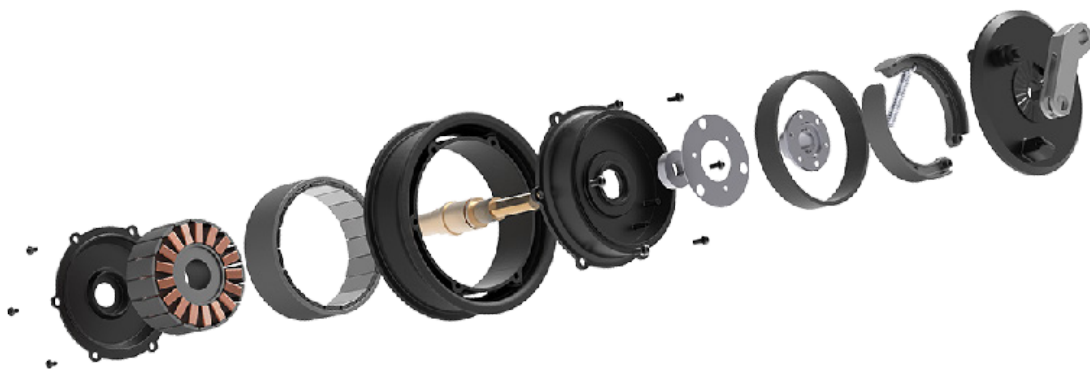

REQUIRED TOOLS

Allen keys set



19 mm ring key



Professional spoons



Tire Pump

Folding INOKIM LIGHT is by one action of pushing the pedal down with your foot

Some people prefer easy folding while some people want the system to be more rigid.

These two facts conflict each other physically. That is why we designed the INOKIM LIGHT Folding Mechanism to be adjustable by the user.

One can tune the folding mechanism to be more rigid or more flexible.

On the next page, we will explain how to adjust the rigidity of the folding mechanism.

NOTICE

INOKIM was assembled by professional people. Any attempt to independently fix or change INOKIM or parts of it in any way, will cause damage to the INOKIM "LIGHT" E-Scooter, and will cancel the manufacturer warranty given upon delivery.

For more rigid feel:

Use Allen Key number 2.5 to release tension on both sides of M4 screws as shown on **Figure 1**.

Then use Allen Key number 2 and gently tight both screws as shown on **Figure 2**.

Test the function and only then, tight back both sides of M4 screws (**Figure 3**)

For easier folding:

Use Allen Key number 2.5 for release tension on both sides of M4 screws as shown on **Figure 1**.

Then use Allen Key number 2 and gently release tension on both screws as shown on **Figure 2**.

Be aware that the distance is only a few millimetres. Be careful that screw will not fall out of their place.

Test the function and only then, tight back both sides of M4 screws (**Figure 3**)

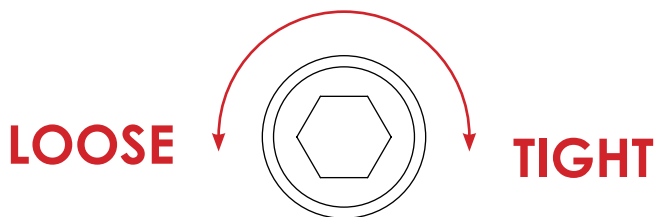
SUMMARY**TIGHT = RIGID MECHANISM****LOOSE = EASY FOLDING**

FOLDING MECHANISM ADJUSTMENT



INOKIM LIGHT MAINTENANCE

To get access to the rear wheel, motor and connectors, use a coin and unscrew the special locker lid, then remove rear plastic covers.

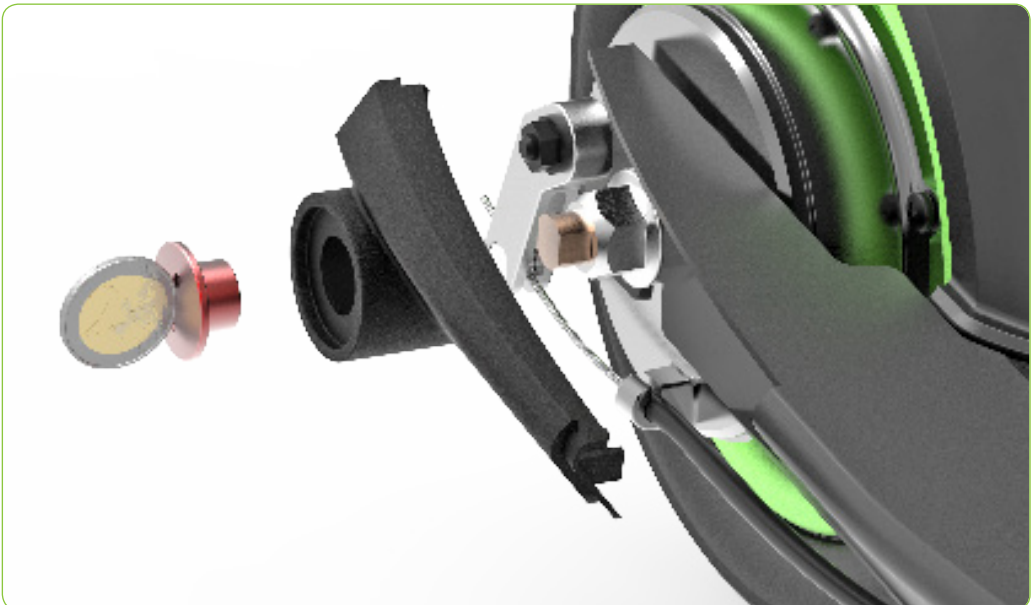

LIGHT

INOKIM LIGHT MAINTENANCE





A word from the designer

Congratulations on your new INOKIM Light.

When I started the design of the MYWAY and/or INOKIM, I envisioned a world where the car would be a secondary vehicle and such lightweight PEVs will be elevated to become a primary vehicle for daily commuters.

After six years of design and development, four years of sales of MYWAY Quick, we are excited to reveal INOKIM LIGHT which offers even a lighter vehicle, faster and easier folding / unfolding great riding experience with an outstanding design appearance.

We created LIGHT to be an integrated part of your life.

We are excited to reveal the INOKIM LIGHT, the most lightweight vehicle in the INOKIM range and the best riding experience you will ever have. We have created the LIGHT so you the rider can seamlessly integrate it into your daily commute.

Enjoy, ride carefully and return safely back home.

Riccardo Nimrod Sapir







Ningbo Myway Intelligent Technology Co.,Ltd
(Head Quarter, Marketing Center, R&D center)
17# Putuoshan Road, Beilun, Ningbo,
ZheJiang Province, China 315806
Tel:0086-574-86133933

WWW.INOKIM.COM | EMAIL: oversea@inokim.com